



tel: 01463 230666 email: info@twinspan.co.uk

SLIDING DOORS

AGS/DR/03

The aim of this instruction manual is to guide you through the process of construction and fitting Sliding Doors. Due to the range of sizes available this instruction is written in a generic form, but should provide sufficient details for you to complete your task successfully. In conjunction with this instruction manual you should refer to specification sheets and details provided by your local distributor. This instruction is a supplement to the Garage Instruction Manual and should be studied prior to the start of construction.

1. Ensure that you have familiarised yourself with all components, that being the description, function and application of each item. Attached are sketches that will aid with this task.
2. During the construction of the building's frame, you are required to fit headers or door bearers to which the door track support brackets will be fitted.
3. For doors fitted to the eave side of the building this header takes the form of an additional eave purlin.

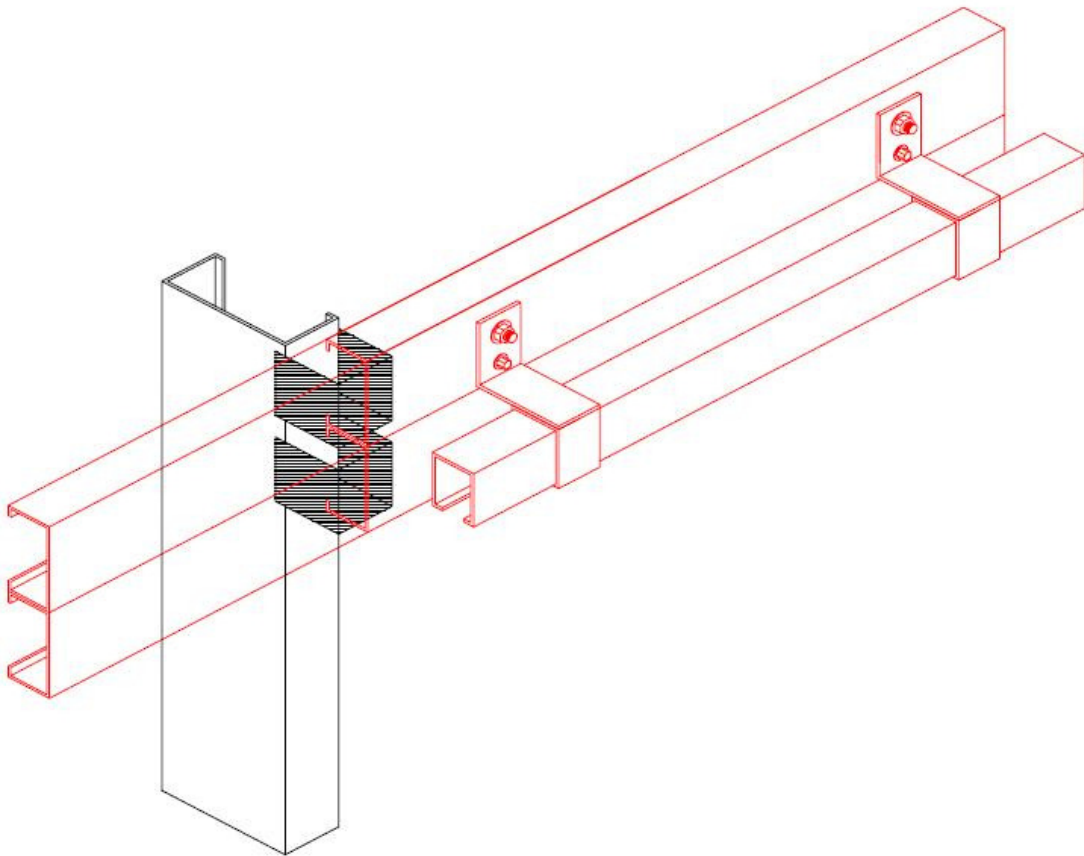

4. Where doors are to be fitted to the gable end of your building a sliding door bearer is to be fitted as per the Gable End Sliding Door Detail, a copy of which is available from your Local Distributor. This beam is fitted web side out and connected to the flange of the side wall columns using the same bracket as the column base connecting brackets.

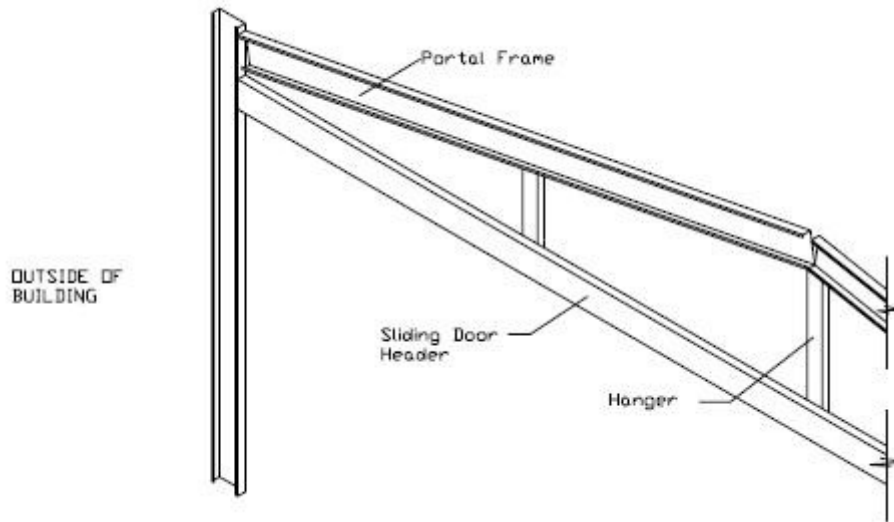

5. The hangers support the centre of the sliding door beam (ensuring it is level and straight). At no more than 3000mm apart with 4 framing screws in each end securing it to the rafter and sliding door beam. Each hanger has a diagonal brace securing it to the roof purlin. See detail below.

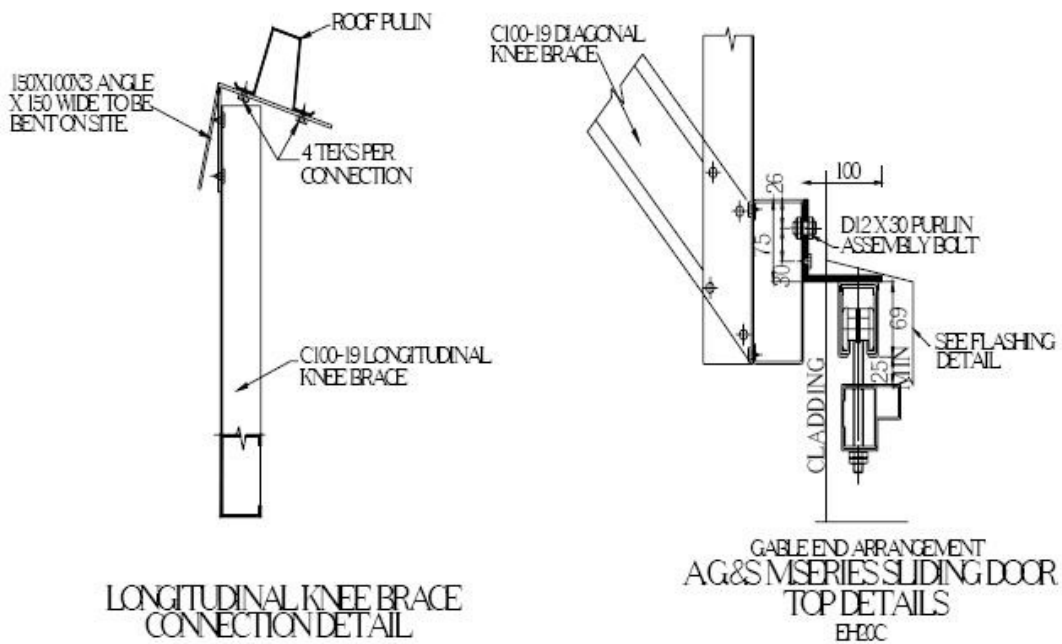

6. Where the entire gable end is to be opened Outriggers may be supplied. This is formed by fixing two columns web to web. A brace is then fitted from half way along the length of the outrigger columns and the other end embedded in the outrigger brace pier. This brace should be at 45 degrees to the outrigger columns. All outrigger columns and braces are embedded in the concrete piers, and have a bracket fitted to the end that prevents the members from sliding when under load once concrete has cured. Further details (including column imbedment in concrete) are available from the structural details sheet.

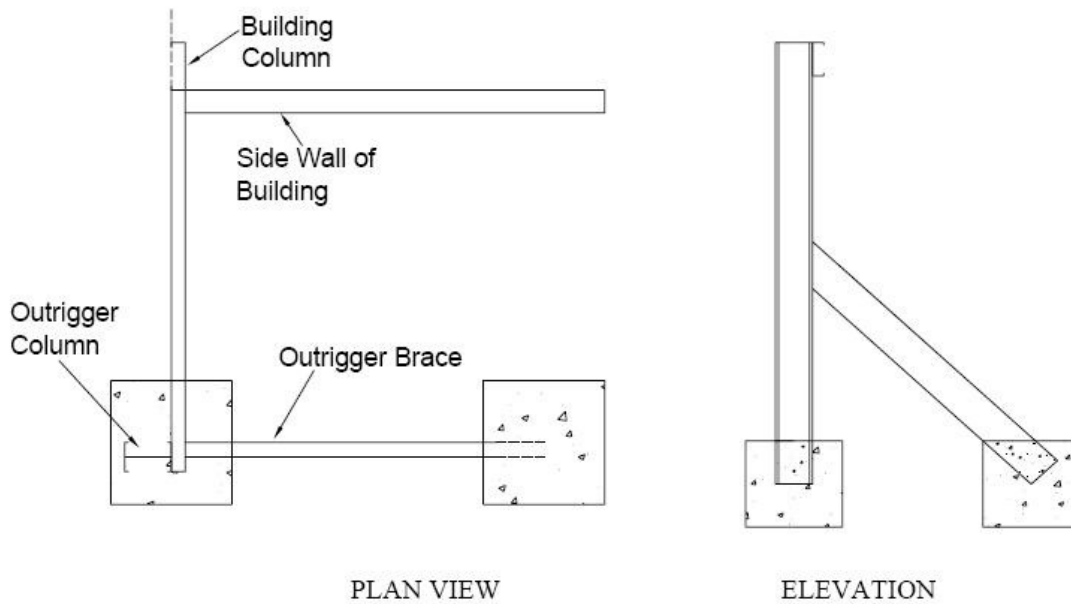

Assembly of Door Frames

7. Layout the lengths of perimeter door framing and backing rail supports ready for assembly as shown below.

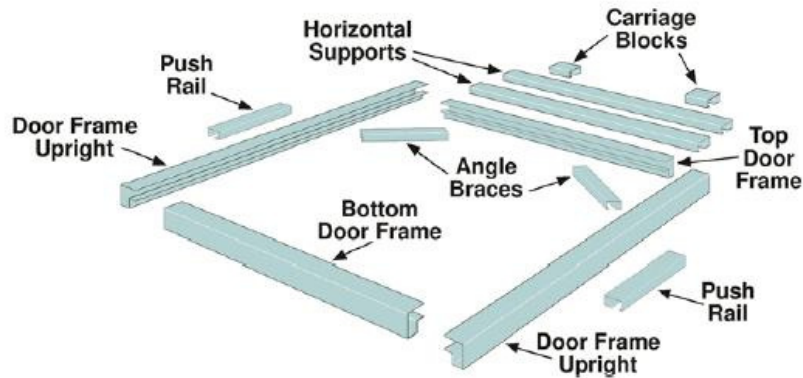

8. Position the perimeter frame sections, check height and width, and fasten with one framing screw in each corner. Square by checking diagonals, and fix with a second screw.

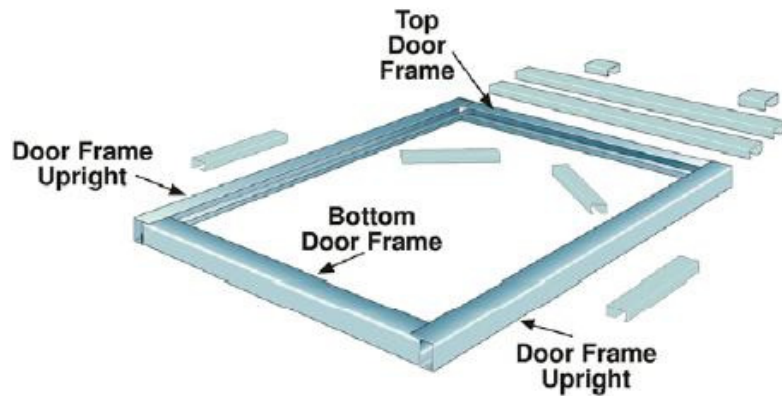

9. Position top corner angle braces, then horizontal backing rail supports. Fix with one framing tek screw only each end.

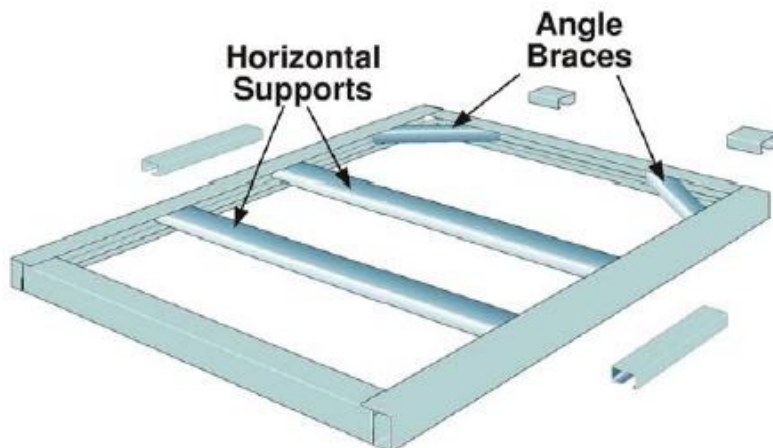

10. Position vertical push rails. Fit carriage mounting blocks.

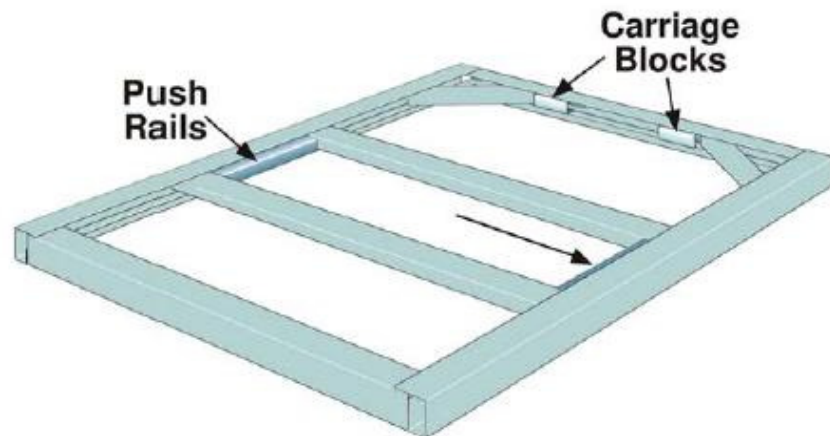

11. Fit door carriages and full length angle door guide.

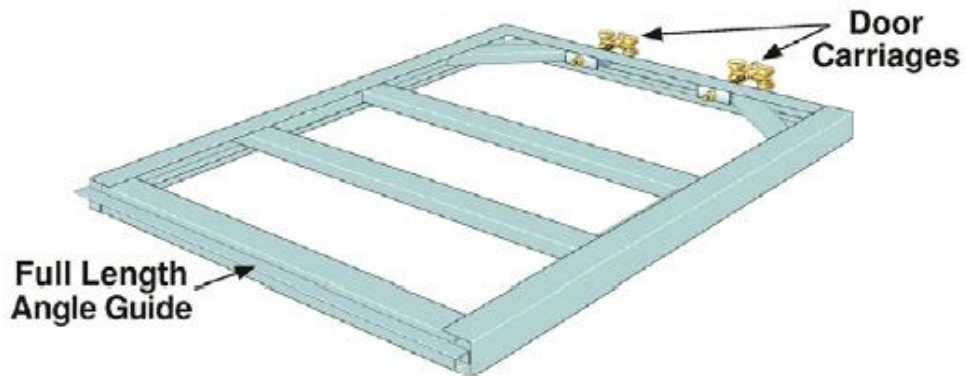

12. Turn over and check for square again, and place a tek screw in each corner only. Fit cladding within the frame recess, tek screw to the frame and horizontal braces via wall screws.

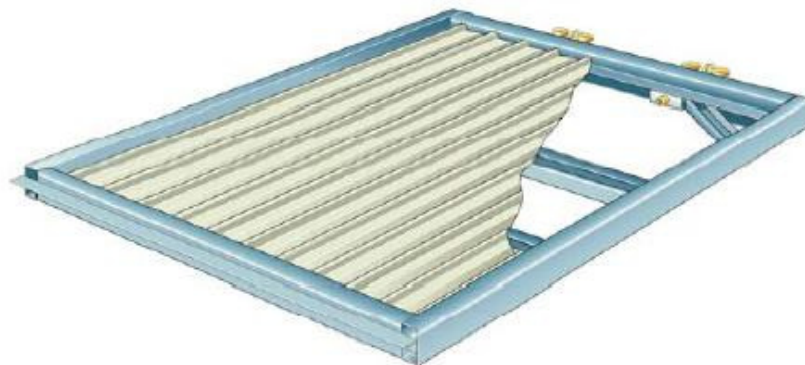

13. Important:

LARGE DOORS MAY BE TOO HEAVY WHEN CLADDED AND WE WOULD RECOMMEND FITTING THE CLADDING AFTER DOOR FRAMES HAVE BEEN INSTALLED ON THE BUILDING.

EAVE SIDE SLIDING DOORS

14. As previously detailed, the sliding door header should have been fitted during the construction of the building.

15. Cladding is fitted to the wall prior to the fitting of sliding door track brackets. Do not fit the gutter until sliding door tracks and flashings are in place.

16. Consideration should be given to the location of storm water down pipes. In some cases the sliding door tracks and flashings will extend the full length of the building, if this applies to your building you will be required to stop the tracks and flashings approximately 150mm short of the end of the building. Depending on the number of down pipes required, this could be either or both ends.

17. Consideration should also be given to the fixing of corner flashings if the door opens from one or both ends of the building. Lengths of wall girt material need to be cut down to column depth, and are to be tek screwed onto the column. This will give support to corner flashing, and will also bring the end wall sheeting out to correct position in line with sliding door.

18. Single track systems will have a track carrying bracket welded to the track support brackets. Double track systems will have a track carrying brackets that are to be bolted on using dome headed bolts that are supplied.

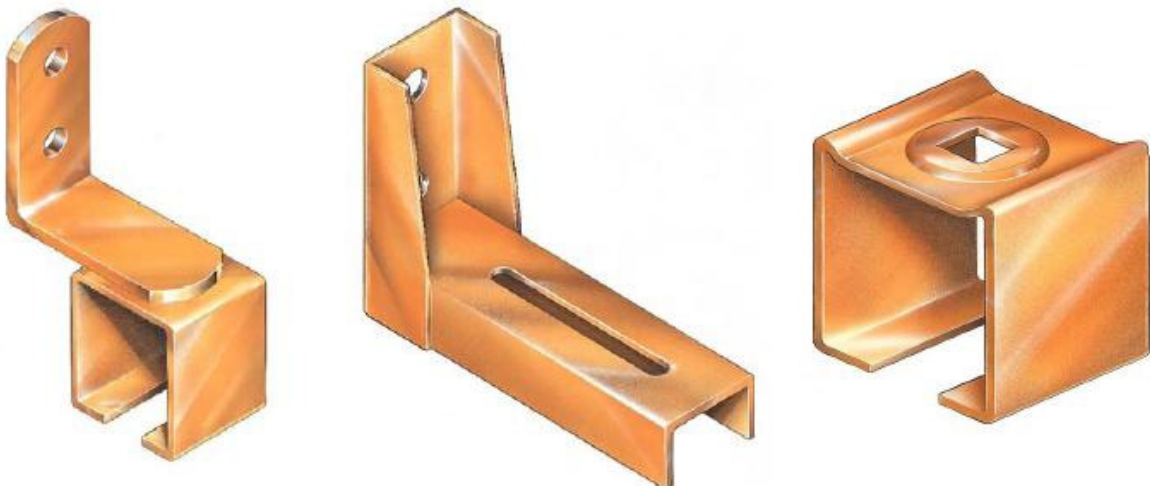

Eltrak Single Track Brkt

Eltrak Double Support Brkt

Eltrak Bolt On Brkt

19. Sliding door track support brackets are then loosely fitted over the cladding (pans not ribs) into the sliding door header prior to the gutter being attached to the building. Each bracket is fitted using bolts supplied and should not be tightened until tracks have been positioned.

20. All brackets are to be evenly spaced and at a maximum of 800mm centre to centre, with the first and last support brackets located approximately 50mm from each end.

21. The height of the brackets can be cross checked by working up from the 25mm rebate in the concrete slab. To the length of the door frame (including the bottom guide angle, but excluding carriage), add 8mm for bottom ground clearance, add 57mm for door track and 25mm for top clearance, the result of this equation will provide a measurement equal to the distance from the footing to the underside of the assembled sliding door support bracket.

22. After all support brackets have been placed in position slide the door tracks into the support brackets and confirm their location before tightening the track support brackets. Where multiple lengths of track are to be connected, track joining brackets are supplied.

23. ENSURE ALL BOLTS, BRACKETS AND CONNECTIONS ARE TIGHT BEFORE PROGRESSING ANY FURTHER. DOUBLE CHECK THAT ALL STEPS IN ASSEMBLING THE DOOR FRAMES HAVE BEEN FOLLOWED.

24. Stand doors and move into place, you may need two people to lift the doors (one each end) and another guiding the door rollers into the track system.

25. The level and height of the door frame is modified using the adjuster nuts on the end of the carriage, leaving the guide at the bottom of the frame 8mm clear of the footing. Once adjusted properly ensure the lock nut is tight against the adjuster nut.



26. Floor Guide Pads are fixed to the footing or concrete floor using 8mm sleeve anchors. A chalk line should be used to mark the line of the door guides. Floor guides are spaced evenly and that spacing should not exceed 50% off the width of the door panels. Floor guides should extend to the extremes of the doors travel ensuring that a block is located at both ends and the centre of the door when it is fully opened or closed.

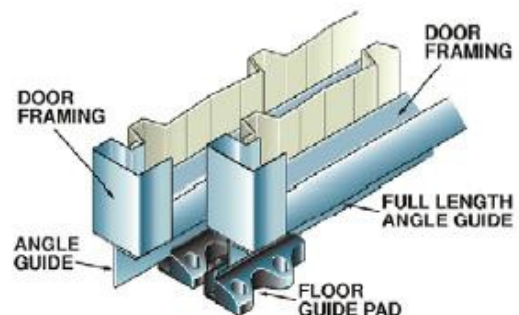

27. Where a double track system has been supplied it is advisable to fit the rear door or doors first. The track bolt on brackets may also need minor adjustments, the rear of the front doors must be clear of the front of the rear doors by no less than 15mm, and no greater than 35mm

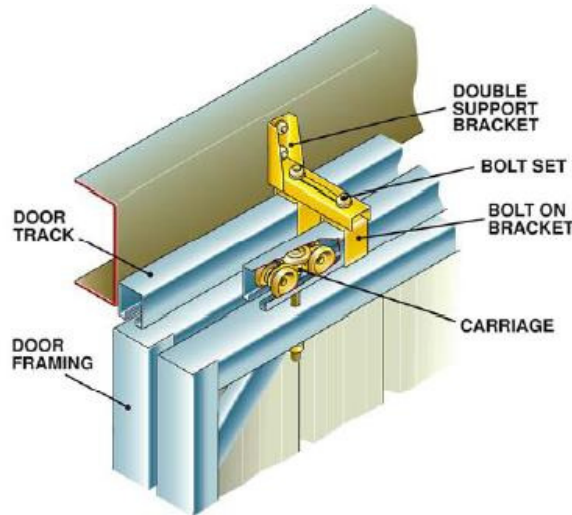

28. Bolt the adjustable flashing brackets (EC50) to the track support brackets. This bracket acts as a stiffener to over door flashing.

29. The over door flashing may now be fitted over the door tracks. This flashing is fixed to the ribs of the wall cladding using pop rivets (supplied). One rivet is fitted to every rib (of the wall cladding) that this flashing crosses and then riveted to the adjustable flashing at 1.0m intervals or where ever needed to straighten flashing. Multiple lengths of flashing should be lapped no less than 50mm and each lap should be sealed with a bead of sealant and fixed with a minimum of two rivets.

30. Track stops are fitted to both ends of every track. This will stop the doors from rolling off the end of tracks.

31. Install gutter over the door flashing.

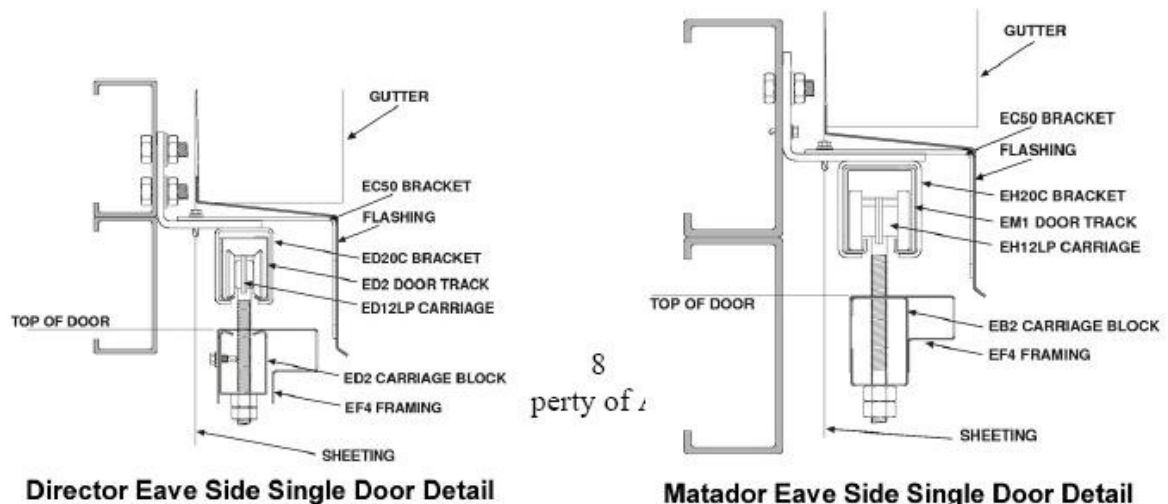

GABLE END SLIDING DOORS

32. As previously detailed, the sliding door header/ bearers and outriggers should be fitted during the construction of the buildings frame.

33. Unlike the eave side application gable end wall cladding is fitted after the installation of the sliding door tracks and flashing.

34. Single track systems will have a track carrying bracket welded to the track support brackets. Double track systems will have a track carrying brackets that are to be bolted on using dome headed bolts that are supplied. **Refer diagrams on page 5.**

35. A level chalk line mark should be placed across the sliding door header beam to indicate the horizontal position of track support brackets.

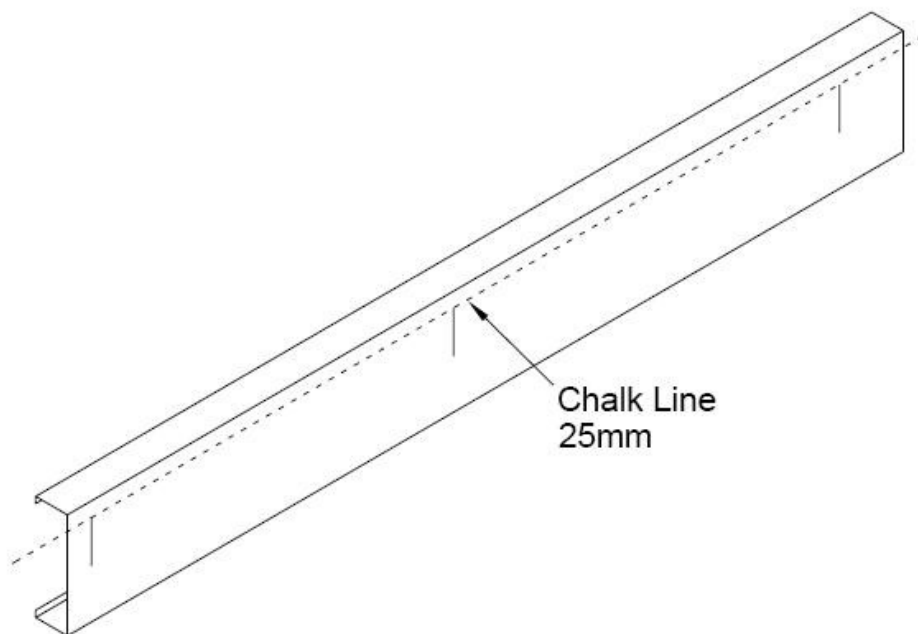

36. Along this chalk line mark positions for the support brackets. These brackets should be evenly spaced at intervals no greater than 800mm. Those brackets at the start and end of the track should be positioned approximately 50mm in from the end of the tracks.

37. Support brackets are then bolted to the header beam, remembering that the chalk line indicates the upper most edge of the back of the bracket. Do not tension the bolts at this stage.

38. The height of the brackets can be crosschecked by working up from the 25mm rebate in the concrete slab. To the length of the door frame (including the bottom guide angle, but excluding carriage), add 8mm for bottom ground clearance, add 57mm for door track and 25mm for top clearance, the result of this equation will provide a measurement equal to the distance from the footing to the underside of the assembled sliding door support bracket.

39. Bolt the adjustable flashing brackets (EC50) to the track support brackets. This bracket acts as a stiffener to over door flashing.

40. After all support brackets have been placed in position slide the door tracks into the support brackets and confirm their location before tightening the track support brackets. Where multiple lengths of track are to be connected, track joining brackets are supplied.

41. ENSURE ALL BOLTS, BRACKETS AND CONNECTORS ARE TIGHT BEFORE PROGRESSING ANY FURTHER. DOUBLE CHECK THAT ALL STEPS IN ASSEMBLING THE DOOR FRAMES HAS BEEN FOLLOWED.



42. Stand doors and move into place, you may need two people to lift the doors (one each end) and another guiding the door rollers into the track system.

43. The level and height of the door frame is modified using the adjuster nuts on the end of the carriage bolt, leaving the guide at the bottom of the frame 8mm clear of the footing. Once adjusted properly ensure the lock nut is tight against the adjuster nut.

44. Floor Guide Pads are fixed to the footing or concrete floor using 8mm sleeve anchors. A chalk line should be used to mark the line of the door guides. Floor guides are spaced evenly and that spacing should not exceed 50% off the width of the door panels. Floor guides should extend to the extremes of the doors travel ensuring that a block is located at both ends and the centre of the door when it is fully opened or closed.

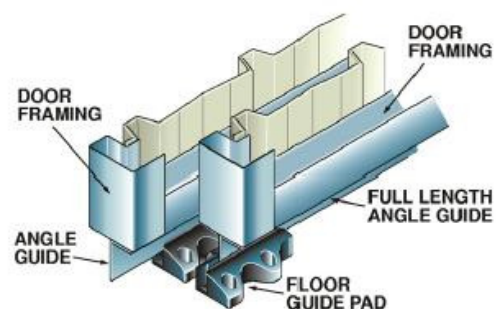

45. Test doors by pushing all frames through the full extent of travel, and make any adjustments that may be required. The action of the door should be smooth and attention should be paid to any bumps that you notice.

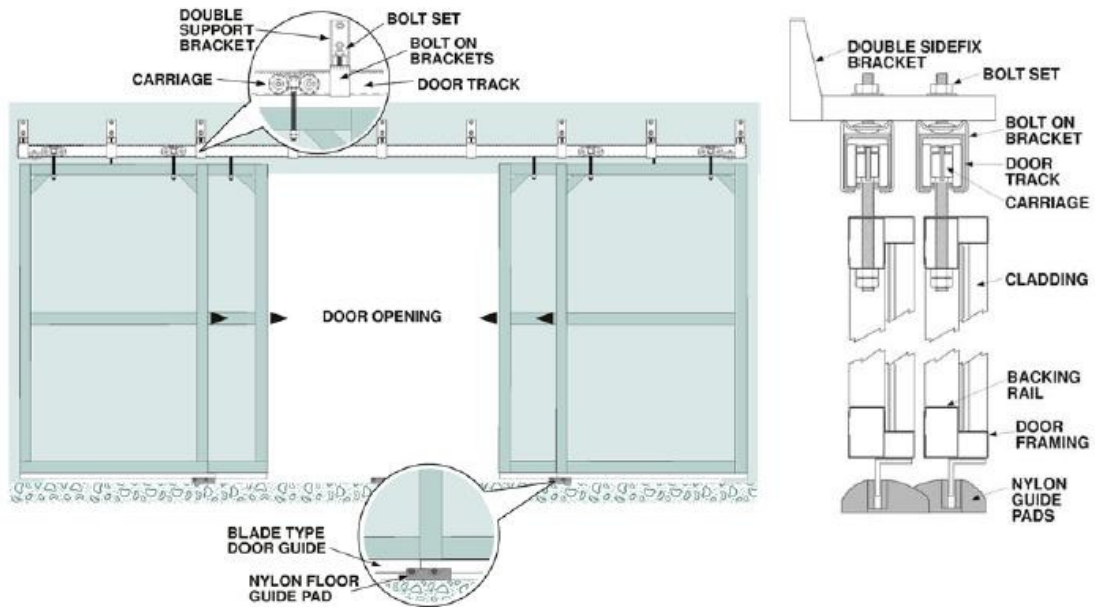

46. Cladding may now be fitted to the door frames if not completed during the assembly of the door frames. Again working on the rear doors first will reduce the risk of damaging cladding. Cladding may need trimming to neatly fit in the rebated frame.

47. Once the cladding of doors is complete, retest the action of all doors and make any final adjustments.

48. Fix weather flashing to header beam using rivits. These screws should be fitted no more than 1000mm apart. Where multiple lengths of flashing are used, flashings should be lapped a minimum of 50mm and sealed with a bead of sealant. Each lap should be fixed with no fewer than 2 rivets.

